

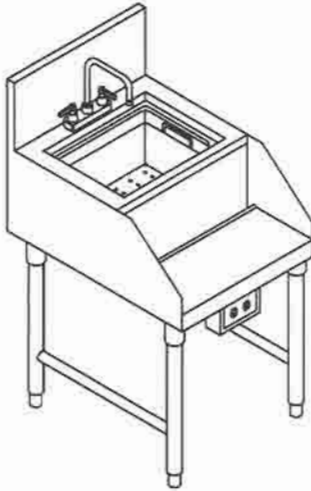

BS MODELS

Recessed Blender Stations

with rectangular sink and H/C faucet



PROJECT _____
 ITEM NO. _____
 QTY. _____
 MODEL NO. _____

For Blender Station less Sink, drop S after B in model number, ex: DB-14

"S" SERIES - 24" DEPTH			# OF BLENDERS		
MODEL	LENGTH	DEPTH	STANDARD	LARGE	SINK
<input type="checkbox"/> SBS-12	12"	24"	1	1	8x9"
<input type="checkbox"/> SBS-14	14"	24"	2	1	8x9"
<input type="checkbox"/> SBS-18	18"	24"	2	2	10x14"
<input type="checkbox"/> SBS-24	24"	24"	3	3	10x14"

"D" SERIES - 29-1/2" DEPTH			# OF BLENDERS		
MODEL	LENGTH	DEPTH	STANDARD	LARGE	SINK
<input type="checkbox"/> DBS-12	12"	29-1/2"	1	1	8x9"
<input type="checkbox"/> DBS-14	14"	29-1/2"	2	1	8x9"
<input type="checkbox"/> DBS-18	18"	29-1/2"	2	2	10x14"
<input type="checkbox"/> DBS-24	24"	29 1/2"	3	3	10x14"

STANDARD FEATURES

- **ALL WELDED CONSTRUCTION** - fully welded, ground and polished to form one integral unit; no screws, pop-rivets or solder.
- **TOP** - 18 gauge #304 series 18-8 stainless steel.
- **FRONT APRON** - 18 gauge #304 series 18-8 stainless steel.
- **BLENDER SHELF** - 14 gauge #304 series 18-8 stainless steel with hidden electrical outlet mounted underneath.
- **BACK** - 18 gauge #304 series 18-8 stainless steel.
- **BOTTOM** - 18 gauge #304 series 18-8 stainless steel.
- **ENDS** - 18 gauge #304 series 18-8 stainless steel.
- **BACKSPASH** - 18 gauge #304 series 18-8 stainless steel.
- **LEG ASSEMBLIES** - 14 gauge s/s channels with heavy-duty s/s gussets, 1-5/8" s/s tube legs and adjustable s/s bullet feet.
- **DECORATIVE POLISHED BULLNOSE**
- **FAUCET** - Chicago or T&S H/C faucet (specify faucet style)

OPTIONS

- CB** -----full cabinet base with removable hinged doors
- PDB** -----perforated dump box
- PR** -----pre-rinse spray faucet (includes installed sleeve in top)
- CRB** -----carbonator shelf under
- SD** -----soap dispenser
- BC6** -----6x6" beverage chase with removable chimney
- M** -----customized

Model Number Guide

Use this guide to create the model specific to your needs.

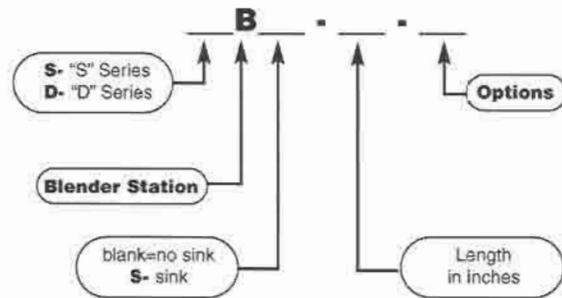

- **ADD-ON BLENDER SHELF** - can be factory installed to any apron. Includes hidden electrical box.

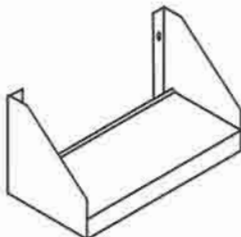

ABS-12 • ABS-14 • ABS-18 • ABS24





BS MODELS

Recessed Blender Stations

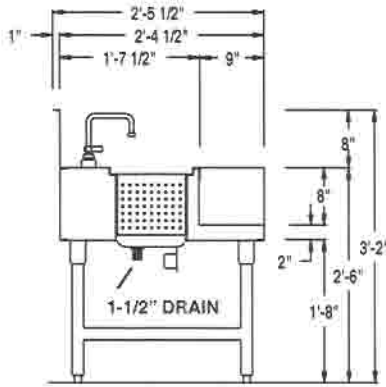

"D" SECTION

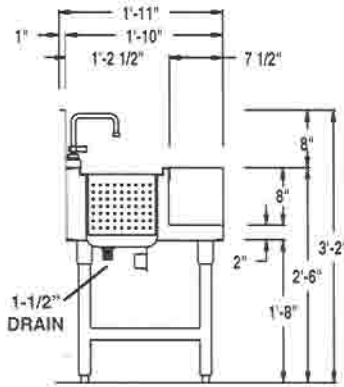

"S" SECTION

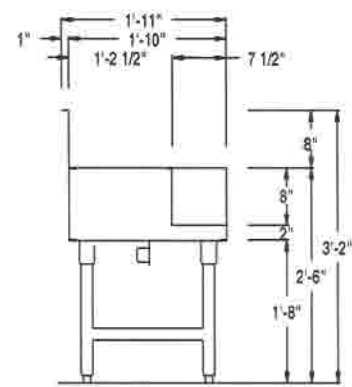

"S" SECTION (Less Sink)

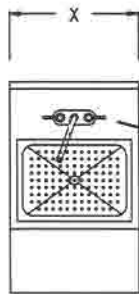

"D" PLAN

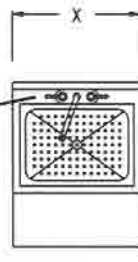

"S" PLAN

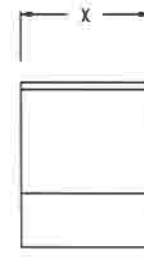

"S" PLAN (Less Sink)

ELEVATION

ELEVATION (Less Sink)

	MODEL	O.A. LENGTH	O.A. DEPTH	STD. BLEND CAP.	LG. BLEND CAP.	SINK SIZE	SHIP WEIGHT	CUBE
"S" SERIES (24" DEEP)	SBS-12	12"	24"	1	1	8"X9"X8"DP	50	5
	SBS-14	14"	24"	2	1	8"X9"X8"DP	55	6
	SBS-18	18"	24"	2	2	10"X14"X10"DP	60	7
	SBS-24	24"	24"	3	3	10"X14"X10"DP	65	9
	SB-12	12"	24"	1	1	N/A	50	5
	SB-14	14"	24"	2	1	N/A	55	6
	SB-18	18"	24"	2	2	N/A	60	7
	SB-24	24"	24"	3	3	N/A	65	9
	"D" SERIES (29 1/2" DEEP)	DBS-12	12"	29-1/2"	1	1	8"X9"X8"DP	50
DBS-14		14"	29-1/2"	2	1	8"X9"X8"DP	55	6
DBS-18		18"	29-1/2"	2	2	10"X14"X10"DP	60	7
DBS-24		24"	29-1/2"	3	3	10"X14"X10"DP	65	9
DB-12		12"	29-1/2"	1	1	N/A	50	5
DB-14		14"	29-1/2"	2	1	N/A	55	6
DB-18		18"	29-1/2"	2	2	N/A	60	7
DB-24		24"	29-1/2"	3	3	N/A	65	9
ADD-ON SHELF		ABS-12	12"	9"	1	1	N/A	5
	ABS-14	14"	9"	2	1	N/A	10	N/A
	ABS-18	18"	9"	2	2	N/A	12	N/A
	ABS-24	24"	9"	3	3	N/A	15	N/A



BS MODELS

Recessed Blender Stations

with rectangular sink and H/C faucet

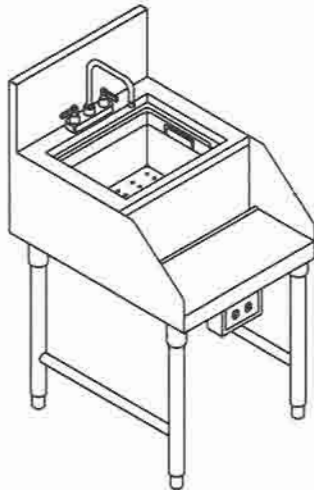

PROJECT _____
 ITEM NO. _____
 QTY. _____
 MODEL NO. _____

For Blender Station less Sink, drop S after B in model number, ex: DB-14

"S" SERIES - 24" DEPTH			# OF BLENDERS		
MODEL	LENGTH	DEPTH	STANDARD	LARGE	SINK
<input type="checkbox"/> SBS-12	12"	24"	1	1	8x9"
<input type="checkbox"/> SBS-14	14"	24"	2	1	8x9"
<input type="checkbox"/> SBS-18	18"	24"	2	2	10x14"
<input type="checkbox"/> SBS-24	24"	24"	3	3	10x14"

"D" SERIES - 29-1/2" DEPTH			# OF BLENDERS		
MODEL	LENGTH	DEPTH	STANDARD	LARGE	SINK
<input type="checkbox"/> DBS-12	12"	29-1/2"	1	1	8x9"
<input type="checkbox"/> DBS-14	14"	29-1/2"	2	1	8x9"
<input type="checkbox"/> DBS-18	18"	29-1/2"	2	2	10x14"
<input type="checkbox"/> DBS-24	24"	29 1/2"	3	3	10x14"

STANDARD FEATURES

- **ALL WELDED CONSTRUCTION** - fully welded, ground and polished to form one integral unit; no screws, pop-rivets or solder.
- **TOP** - 18 gauge #304 series 18-8 stainless steel.
- **FRONT APRON** - 18 gauge #304 series 18-8 stainless steel.
- **BLENDER SHELF** - 14 gauge #304 series 18-8 stainless steel with hidden electrical outlet mounted underneath.
- **BACK** - 18 gauge #304 series 18-8 stainless steel.
- **BOTTOM** - 18 gauge #304 series 18-8 stainless steel.
- **ENDS** - 18 gauge #304 series 18-8 stainless steel.
- **BACKSPLASH** - 18 gauge #304 series 18-8 stainless steel.
- **LEG ASSEMBLIES** - 14 gauge s/s channels with heavy-duty s/s gussets, 1-5/8" s/s tube legs and adjustable s/s bullet feet.
- **DECORATIVE POLISHED BULLNOSE**
- **FAUCET** - Chicago or T&S H/C faucet (specify faucet style)

- **ADD-ON BLENDER SHELF** - can be factory installed to any apron. Includes hidden electrical box.

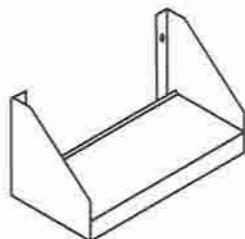

ABS-12 • ABS-14 • ABS-18 • ABS-24

OPTIONS

- CB** -----full cabinet base with removable hinged doors
- PDB** -----perforated dump box
- PR** -----pre-rinse spray faucet (includes installed sleeve in top)
- CRB** -----carbonator shelf under
- SD** -----soap dispenser
- BC6** -----6x6" beverage chase with removable chimney
- M** -----customized

Model Number Guide

Use this guide to create the model specific to your needs.

