

VL SERIES



SPT MODELS

Pass-Thru Ice Chest

with 8 circuit cold plate

PROJECT _____
 ITEM NO. _____
 QTY. _____
 MODEL NO. _____

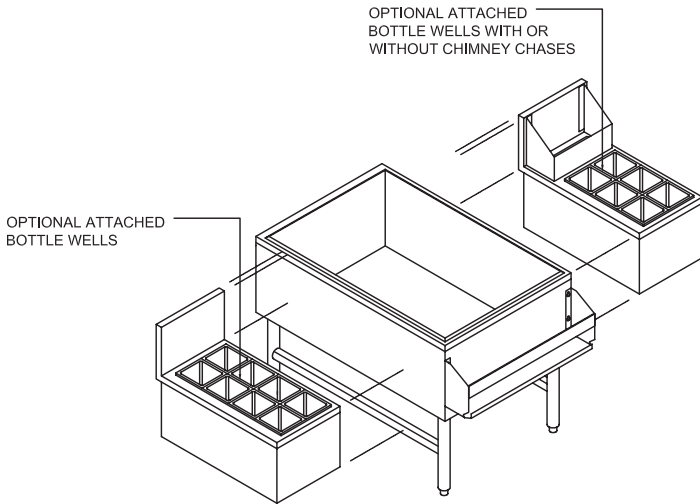

"S" SERIES

	LINE	MODEL	LENGTH	DEPTH	ICE CAP.
<input type="checkbox"/>	VL	SPT-24P8	24"	36"	150

For Pass-Thru less Cold Plate, drop P8 from end of model number, ex: SPT-48

OPTIONS

- CB**----- full cabinet base with removable hinged doors
- P10**----- 10 circuit cold plate
- P12**----- 12 circuit cold plate
- CR-#** ----- condiment rail (specify # of pans)
- SBC-3** ----- 3 bottle well unit
- SBC-4** ----- 4 bottle well unit
- SBC-6** ----- 6 bottle well unit
- SBC-8** ----- 8 bottle well unit
- SBC-6C**---- 6 bottle well unit w/ chimney
- SBC-3C**--- 3 bottle well unit w/ chimney
- PRF** ----- perforated bottom plate (only in non-cold plate units)
- M**----- customized

STANDARD FEATURES

- **ALL WELDED CONSTRUCTION** - fully welded, ground and polished to form one integral unit; no screws, pop-rivets or solder.
- **TOP** - 18 ga. #304 series, stainless steel.
- **FRONT & BACK APRON** - 20 ga. #304 series, stainless steel.
- **BACK** 20 ga. #304 series, stainless steel.
- **BOTTOM** 20 ga. #304 series, stainless steel.
- **ENDS** 20 ga. #304 series, stainless steel.
- **BACKSPLASH** - 18 ga. #304 series, stainless steel.
- **ICE CHEST LINER** - 12-1/2" net deep, 18 gauge #304 series stainless steel all welded with 3/8" radius corners.
- **8 CIRCUIT FAST-FLO SEALED-IN COLD PLATE**
- **INSULATION** - polyurethane shot-in-place foam (NO CFC's).
- **ICC** - sliding ice chest cover

Model Number Guide

Use this guide to create the model specific to your needs.

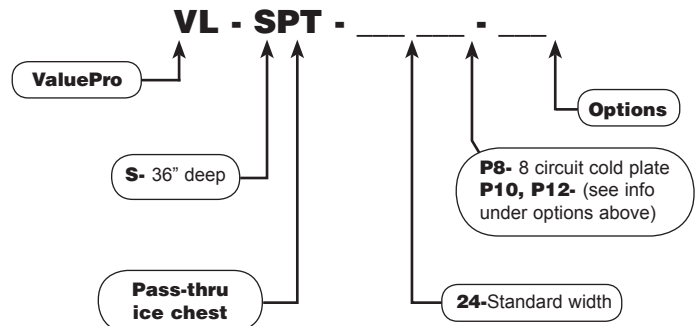

VL SERIES



SPT MODELS

Pass-Thru Ice Chest

with 8 circuit cold plate

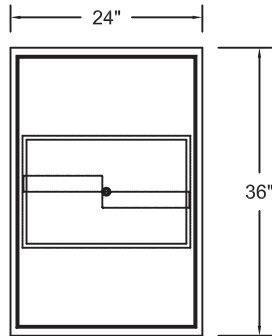

PLAN

"S" SERIES 36" DEEP

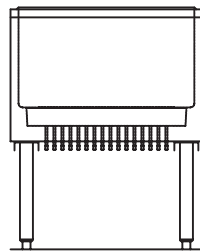

ELEVATION

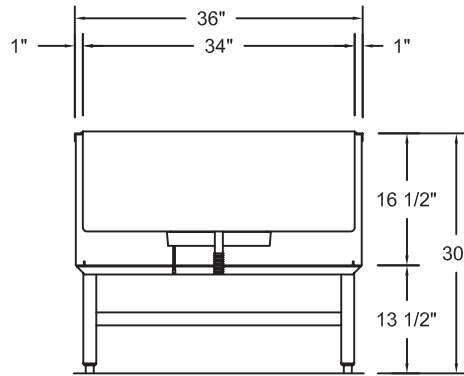

SECTION