

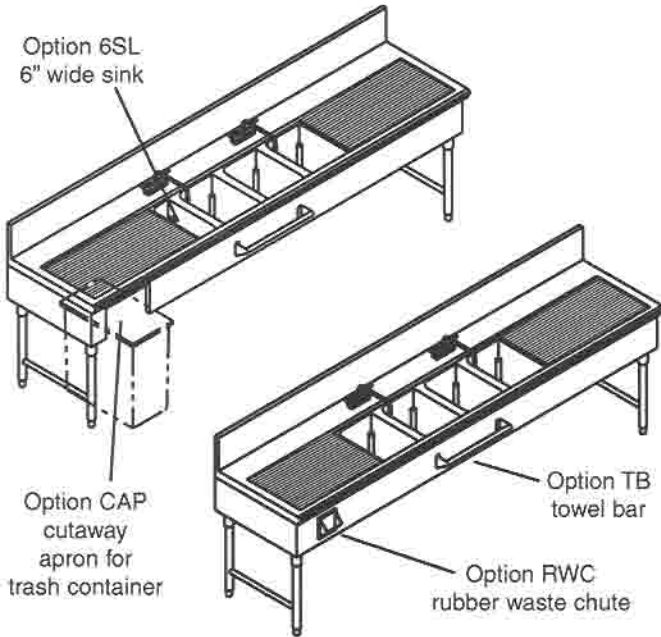

4C MODELS

4 Bowl Glass Washing Sinks



PROJECT _____
 ITEM NO. _____
 QTY. _____
 MODEL NO. _____

	"S" SERIES	"D" SERIES	OVERALL LENGTH	DRAINBOARD LENGTH	
	20.5" DEPTH	24" DEPTH		LEFT	RIGHT
<input type="checkbox"/>	S4C-48	D4C-48	48"	0	0
<input type="checkbox"/>	S4C-72	D4C-72	72"	12"	12"
<input type="checkbox"/>	S4C-84	D4C-84	84"	18"	18"
<input type="checkbox"/>	S4C-96	D4C-96	96"	24"	24"
<input type="checkbox"/>	S4C-108	D4C-108	108"	30"	30"
<input type="checkbox"/>	S4C-120	D4C-120	120"	36"	36"

OPTIONS

- 6SL** -----6" wide dump sink with s/s lift-out strainer far left hand bowl
- 6SR** -----6" wide dump sink with s/s lift-out strainer far right hand bowl
- CB** -----full cabinet base with removable hinged door
- 15S** -----15" x 15" x 14" deep sink bowls
- RWC** -----rubber waste chute factory installed into front apron
- REC18** ----NSF approved 18" high trash receptacle for #RWC waste chute
- CAP** -----cut-away apron for trash container
- REC26** ----NSF approved 26" high trash receptacle for #CAP cut-away apron
- TB** -----18" wide factory installed towel bar
- PDB** -----s/s dump box strainer for 10x14 sink
- GR20** -----glass rack storage slides on legs accomodates (3) 20x20 racks. Includes cut-away apron. (Requires 24" drainboard min.)
- GR20C** ----glass rack storage cabinet accomodates (3) 20x20 racks. Includes cut-away apron. (Requires 24" drainboard min.)
- US** -----s/s undershelf (specify location & length)
- PR** -----pre-rinse spray faucet (includes installed sleeve in top)
- BN** -----decorative polished bullnose
- M** -----customized

Model Number Guide

Use this guide to create the model specific to your needs.

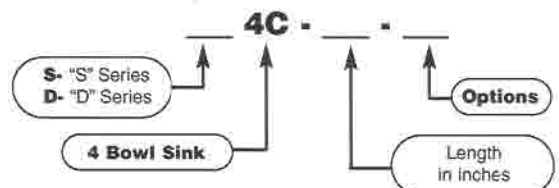

STANDARD FEATURES

- **ALL WELDED CONSTRUCTION** - fully welded, ground and polished to form one integral unit; no screws, pop-rivets or solder.
- **DRAINBOARDS** - 18 gauge #304 series 18-8 stainless steel full-length continuous "WWW" corrugation pitches to bowls and is reinforced with 4" wide 14 gauge s/s inverted U-channels welded underneath and sound deadened.
- **SINK COMPARTMENTS** - 18 gauge deep-drawn stainless steel. Each bowl measures 10"W x 14"D x 10"H with 1-1/2" waste and stand pipe.
- **TOP** - 18 gauge #304 series 18-8 stainless steel.
- **FRONT APRON** - 18 gauge #304 series 18-8 stainless steel with access hole for plug.
- **BACK** - 18 gauge #304 series 18-8 stainless steel.
- **BOTTOM** - 18 gauge #304 series 18-8 stainless steel.
- **ENDS** - 18 gauge #304 series 18-8 stainless steel.
- **BACKSPLASH** - 18 gauge #304 series 18-8 stainless steel.
- **LEG ASSEMBLIES** - 14 gauge s/s channels with heavy-duty s/s gussets, 1-5/8" s/s tube legs and adjustable s/s bullet feet.
- **FAUCET** - Chicago H/C faucet (specify other type if needed)





4C MODELS

4 Bowl Glass Washing Sinks

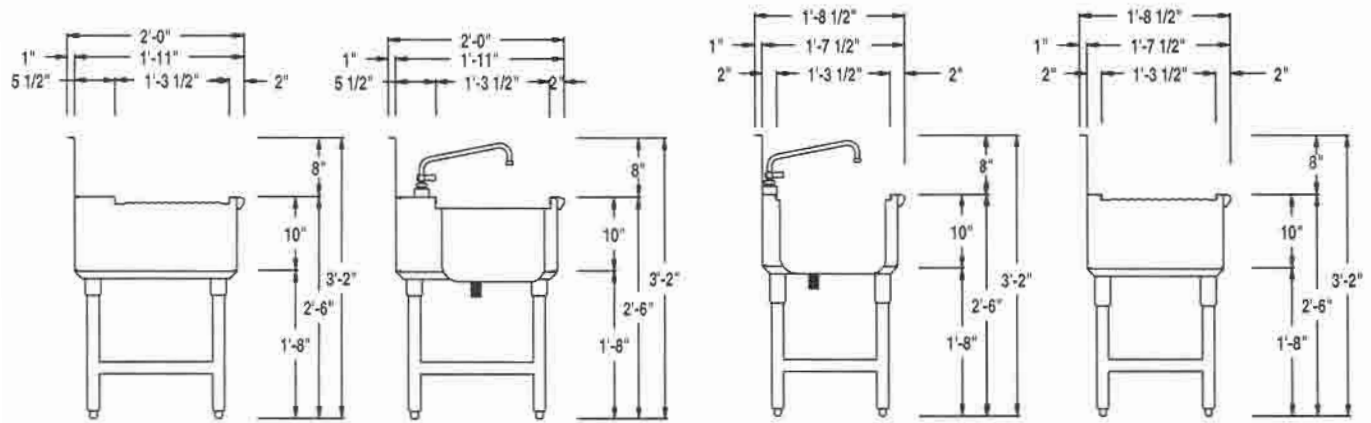

"D" SECTIONS

"S" SECTIONS

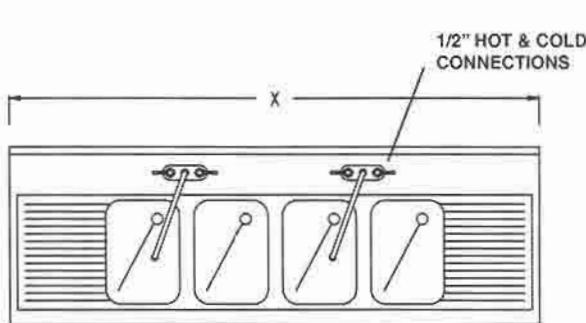

"D" PLAN

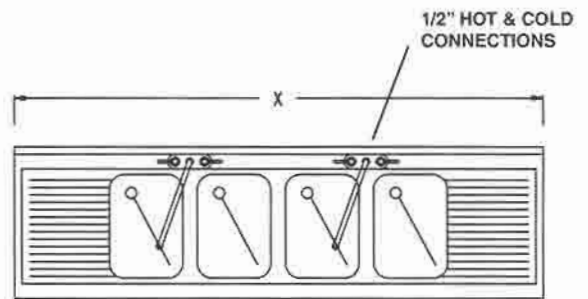

"S" PLAN

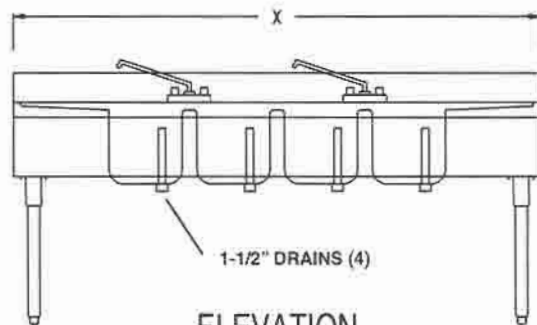

ELEVATION

"S" SERIES			"D" SERIES			OVERALL LENGTH	L DB LENGTH	R DB LENGTH	SHIP WEIGHT	CUBE
MODEL	SQ. INCH. DRNB.	REAR DECK	MODEL	SQ. INCH. DRNB.	REAR DECK					
S4C-48	0	2"	D4C-48	0	5-1/2"	48"	0	0	125	13
S4C-72	416	2"	D4C-72	416	5-1/2"	72"	12"	12"	185	38
S4C-84	544	2"	D4C-84	544	5-1/2"	84"	18"	18"	200	44
S4C-96	736	2"	D4C-96	736	5-1/2"	96"	24"	24"	240	50
S4C-108	464	2"	D4C-108	464	5-1/2"	108"	30"	30"	285	55
S4C-120	560	2"	D4C-120	560	5-1/2"	120"	36"	36"	320	61